

Decompositions of automata and transition semigroups *

Tatjana Petković[†] Miroslav Ćirić[‡] Stojan Bogdanović[§]

Abstract

The purpose of this paper is to describe structural properties of automata whose transition semigroups have a zero, left zero, right zero or bi-zero, or are nilpotent extensions of rectangular bands, left zero bands or right zero bands, or are nilpotent. To describe the structure of these automata we use various well-known decomposition methods of automata theory – direct sum decompositions, subdirect and parallel decompositions, and extensions of automata. Automata that appear as the components in these decompositions belong to some well-known classes of automata, such as directable, definite, reverse definite, generalized definite and nilpotent automata. But, we also introduce some new classes of automata: generalized directable, trapped, one-trapped, locally directable, locally one-trapped, locally nilpotent and locally definite automata. We explain relationships between the classes of all these automata.

Keywords: automaton, transition semigroup, direct sum decomposition, directable automata, trapped automata, generalized directable automata, locally directable automata, generalized varieties.

1. Introduction and preliminaries

Transition semigroups of automata were first defined and studied by V. M. Glushkov in [16], 1961. The systematic study of relationships between the structure of automata and their transition semigroups was initiated by I. Peák in [23], 1964, and [24], 1965, and after that many authors worked on this important topic. Many of the results concerning this topic were collected in the book of F. Gécseg and I. Peák [14], in 1972, and in some other books.

*Supported by Grant 04M03B of RFNS through Math. Inst. SANU.

[†]University of Niš, Faculty of Philosophy, Ćirila i Metodija 2, P. O. Box 91, 18000 Niš, Yugoslavia, e-mail: tanjapet@archimed.filfak.ni.ac.yu

[‡]University of Niš, Faculty of Philosophy, Ćirila i Metodija 2, P. O. Box 91, 18000 Niš, Yugoslavia, e-mail: mciric@archimed.filfak.ni.ac.yu

[§]University of Niš, Faculty of Economics, Trg VJ 11, P. O. Box 121, 18000 Niš, Yugoslavia, e-mail: sbogdan@archimed.filfak.ni.ac.yu

The main aim of the present paper is to investigate structural properties of automata whose transition semigroups have some interesting properties, such as: to have a zero, left zero, right zero or bi-zero, to be a nilpotent extension of a rectangular band, left zero band or right zero band, to be nilpotent, etc. To describe the structure of these automata we use various well-known decomposition methods of automata theory, such as direct sum decompositions, subdirect and parallel decompositions, and extensions of automata. Automata that appear as the components in these decompositions belong to some well-known classes of automata. These are directable automata, introduced by P. H. Starke in [30] and J. Černý in [7], definite automata, defined first by S. C. Kleene in [20], and M. Perles, M. O. Rabin and E. Shamir in [25], reverse definite automata, introduced by J. A. Brzozowski in [5], and A. Ginzburg in [15], generalized definite automata, defined also by A. Ginzburg in [15], and nilpotent automata, that appeared first in the paper of L. N. Shevrin [29], and the book [14] by F. Gécseg and I. Peák. These automata were also studied by J. Černý, A. Piricka and B. Rosenauerová in [8], M. Ito and J. Duske in [19], J. E. Pin in [26], [27] and [28], M. Steinby in [31], and others. These types of automata were recently investigated by B. Imreh and M. Steinby in [18].

However, it is also necessary to introduce some new classes of automata. In Section 2 we define and study some new types of automata: generalized directable automata, trapped automata, one-trapped automata, locally directable automata and locally one-trapped automata. In Section 3 we introduce locally nilpotent and locally definite automata, and we connect them with nilpotent, definite, reverse definite and generalized automata. Relationships between these types of automata will be explained in Section 4, where the classes of these automata will be treated as generalized varieties. Note that the concept of an automaton 'belonging locally' to a given class of automata was introduced by M. Steinby in [32].

Automata considered throughout this paper will be automata without outputs in the sense of the definition from the book of F. Gécseg and I. Peák [14]. It is well known that automata without outputs, with the input alphabet X , can be considered as unary algebras of type indexed by X (we will say that they are of type X). This will be done throughout this paper. The notions such as a *congruence*, *subautomaton*, *generating set* etc., will have their usual algebraic meanings. In order to simplify notations, an automaton with the state set A will be also denoted by the same letter A . For any considered automaton A , its input alphabet will be denoted by X . In this paper we will aim our attention only to the case $|X| \geq 2$. The free monoid over X , i.e. the input monoid of A , is denoted by X^* and free semigroup over X is denoted by X^+ . Under action of an input word $u \in X^*$, the automaton A goes from a state a into the state that will be denoted by au . For an arbitrary $k \in \mathbb{N}$, where \mathbb{N} denotes the set of all positive integers, we denote by X^k the set of all words having the length k , and by $X^{\geq k}$ the set of all words of the length at least k .

The *transition semigroup* $S = S(A)$ of an automaton A , in some origins called the *characteristic semigroup* of A , one can define in two equivalent ways. The first one is to define $S(A)$ as a semigroup consisting of all *transition mappings* on A ,

by which we mean the mappings η_u , $u \in X^+$, defined by: $a\eta_u = au$, for $a \in A$. Another way is to define $S(A)$ to be the factor semigroup of the input semigroup X^+ with respect to the *Myhill congruence* μ on X^+ defined by: $(u, v) \in \mu$ if and only if $au = av$, for each $a \in A$. Note that $(u, v) \in \mu$ if and only if $\eta_u = \eta_v$. We will use the first way mostly.

Rees congruences, a famous notion of semigroup theory, have their analogues in many other theories. It appears that in automata theory they were first defined by I. Babcsányi in [2]. The *Rees congruence* on an automaton A determined by a subautomaton B of A is a congruence θ defined in the following way: For $a, b \in A$ we say that $(a, b) \in \theta$ if and only if either $a = b$ or $a, b \in B$ holds. The factor automaton A/θ is usually denoted by A/B , and it is called a *Rees factor automaton* of A with respect to B . If B is a subautomaton of an automaton A and the Rees factor automaton A/B is isomorphic to an automaton C , we say that A is an *extension* of an automaton B by an automaton C . Clearly, the automaton C can be viewed as an automaton obtained from A by contraction of B into a single element. In other words, C is isomorphic to the automaton D defined in the following way: $D = (A \setminus B) \cup \{a_0\}$, where a_0 does not belong to A , and the transitions in D are defined by

$$ax = \begin{cases} ax, & \text{as in } A, \text{ if } a, ax \in A \setminus B \\ a_0, & \text{if } a \in A \setminus B \text{ and } ax \notin A \setminus B, \text{ or } a = a_0 \end{cases}$$

We will usually identify the automata C and D .

Another notion imported from semigroup theory is the following: If there exists a homomorphism φ of an automaton onto its subautomaton B such that $a\varphi = a$, for each $a \in B$, then this homomorphism is called a *retraction* of A onto B and we say that A is a *retractive extension* of B by A/B .

An automaton A is a *direct sum* of its subautomata A_α , $\alpha \in Y$, if $A = \bigcup_{\alpha \in Y} A_\alpha$ and $A_\alpha \cap A_\beta = \emptyset$ for all $\alpha, \beta \in Y$ such that $\alpha \neq \beta$. The equivalence relation that correspond to this partition of A is a congruence and it is called a *direct sum congruence* on A . More information about general properties of direct sum decompositions of automata can be found in [10]. Finally, we say that an automaton A is a *parallel composition* of automata B and C if it can be embedded into their direct product.

For the notions and notations which are not explicitly defined here we refer to [6], [14] and [17].

2. Generalized directable automata

As it was announced in the introduction, we will investigate automata whose transition semigroups have some kinds of zeroes. Recall that an element e of a semigroup S is called a *left zero* of S if $es = e$, for each $s \in S$, a *right zero* of S if $se = e$, for each $s \in S$, and a *zero* of S , if it is both a left and a right zero of S . As a generalization of these notions we introduce the following notion: An element e of

a semigroup S will be called a *bi-zero* of S if $ese = e$, for each $s \in S$. First we describe semigroups having left, right or bi-zeroes.

Lemma 1. *A semigroup S has a bi-zero (resp. left zero, right zero) if and only if it is an ideal extension of a rectangular (resp. left zero, right zero) band.*

If e and f are bi-zeroes of S , then $esf = ef$, for each $s \in S$.

Proof. Suppose that S has a bi-zero. Let E denote the set of all bi-zeroes of S . For an arbitrary $e \in E$ we have $e^3 = e$ and $e^4 = ee^2e = e$, whence $e^2 = e$. Thus, E is a band, and clearly, it is a rectangular band. On the other hand, for $e \in E$ and $s, t \in S$ we have that $(es)t(es) = e(st)es = es$ and $(se)t(se) = se(ts)e = se$. Therefore, $es, se \in E$, so E is an ideal of S , which was to be proved.

Conversely, let S be an ideal extension of a rectangular band E . Assume arbitrary $e \in E$ and $s \in S$. Then $es \in E$, whence $ese = e(es)e = e$. Thus, e is a bi-zero of S .

The assertions concerning left and right zeroes can be proved similarly.

In the above notations, assume arbitrary $e, f \in E$ and $s \in S$. Then $sf \in E$ and $f = fef$, whence $esf = es(fef) = e(sf)ef = ef$. This completes the proof of the lemma. \square

Using the previous one, we prove another lemma:

Lemma 2. *Let a semigroup S has a left (resp. right) zero. Then the set of all left (resp. right) zeroes of S coincides with the set of all bi-zeroes of S .*

If S has a zero, then it is unique and S does not have other left, right or bi-zeroes.

Proof. Let L and B denote the set of all left zeroes and the set of all bi-zeroes of S , respectively. Obviously, $L \subseteq B$. Assume an arbitrary $f \in B$. Then $f = fef$. But, by Lemma 1, L is an ideal of S , whence $f \in SLS \subseteq L$. Therefore, $L = B$.

The remaining assertions one proves similarly. \square

Now we are passing from semigroups to automata. First we recall some known notions. An automaton A is called a *directable automaton* if there exists a word $u \in X^*$ such that $au = bu$, for all $a, b \in A$. Such word is called a *directable word* and the set of all directable words of A is denoted by $DW(A)$.

A state a of A is called a *trap* of A if $au = a$, for each $u \in X^*$, that is, if the set $\{a\}$ is a subautomaton of A [21]. If A has exactly one trap, it is called a *one-trap automaton* [3]. The set of all traps of A will be denoted by $Tr(A)$. An automaton whose each state is a trap is called a *discrete automaton* [13].

The first new notion that we introduce is the following: An automaton A will be called a *trapped automaton* if there exists a word $u \in X^*$ such that $au \in Tr(A)$, for each $a \in A$. Such word will be called a *trapping word*, and the set of all trapping words of A will be denoted by $TW(A)$. In other words, $u \in TW(A)$ if and only if $auv = au$, for all $a \in A$ and $v \in X^*$. We also define an automaton A to be a *one-trapped automaton* if it is trapped and has exactly one trap. It is not hard to

verify that A is a one-trapped automaton if and only if there exists $u \in X^*$ such that $auv = bu$, for all $a, b \in A$ and $v \in X^*$.

Third, we generalize directable automata as follows: An automaton A will be called a *locally directable automaton* if all monogenic subautomata of A are directable and they have common directing word. Here by a *monogenic subautomaton* we call a subautomaton generated by a single state (called also *cyclic*). The condition that all monogenic subautomata must have the same directing word is fulfilled in each finite automaton, that is, a finite automaton is locally directable if and only if all its monogenic subautomata are directable. Equivalently, A is locally directable if there exists $u \in X^*$ such that $avu = au$, for all $a \in A$ and $v \in X^*$. Such word will be called a *locally directing word*, and the set of all locally directing words of A will be denoted by $LDW(A)$.

Similarly, an automaton A will be called a *locally one-trapped automaton* if all monogenic subautomata of A are one-trapped automata and they have common trapping word. Such words will be called a *locally one-trapping word* of A and the set of all such words will be denoted by $LOTW(A)$. In other words, A is a locally one-trapped automaton if and only if there exists $u \in X^*$ such that $apuq = au$, for all $a \in A$ and $p, q \in X^*$. A finite automaton is locally one-trapped if and only if all its monogenic subautomata are one-trapped.

The fifth new notion that we introduce here is a common generalization of directable, locally directable and trapped automata. Namely, an automaton A is said to be a *generalized directable automaton* if there exists $u \in X^*$ such that $auvu = au$, for all $a \in A$ and $v \in X^*$. Such word will be called a *generalized directing word* of A . The set of all generalized directing words of an automaton A will be denoted by $GDW(A)$. We have chosen these names because an analogy with generalized definite automata, that will be considered in the next section.

The following lemma, that can be easily checked, establishes some relationships between these automata and the above considered semigroups.

Lemma 3. *Let A be an automaton and $u \in X^*$. Then $u \in GDW(A)$ (resp. $u \in TW(A)$, $u \in LDW(A)$, $u \in LOTW(A)$) if and only if η_u is a bi-zero (resp. left zero, right zero, zero) of $S(A)$.*

The next lemma is an immediate consequence of Lemmas 1, 2 and 3.

Lemma 4. *For an automaton A , $GDW(A)$, $TW(A)$ and $LDW(A)$ are ideals of X^* . Moreover, the following conditions hold:*

- (1) $TW(A) \neq \emptyset$ implies $TW(A) = GDW(A)$;
- (2) $LDW(A) \neq \emptyset$ implies $LDW(A) = GDW(A)$;
- (3) $LOTW(A) \neq \emptyset$ implies $LOTW(A) = LDW(A) = TW(A) = GDW(A)$;
- (4) $TW(A) \neq \emptyset$ and $LDW(A) \neq \emptyset$ implies $LOTW(A) \neq \emptyset$.

Now we are ready to prove one of the main theorems of the paper.

Theorem 1. *The following conditions on an automaton A are equivalent:*

- (i) $S(A)$ has a bi-zero;
- (ii) A is an extension of a locally directable automaton by an one-trapped automaton;
- (iii) A is a generalized directable automaton.

Proof. (i) \Leftrightarrow (iii). This follows by Lemma 3.

(iii) \Rightarrow (ii). Let $B = \{au \mid a \in A, u \in GDW(A)\}$. Since $GDW(A)$ is an ideal of X^* , B is a subautomaton of A . Let a_0 be the trap of A/B which is the image of B under the natural homomorphism of A onto A/B . For arbitrary $a \in A \setminus B$ and $u \in GDW(A)$ we have that $au \in B$ in A , that is $au = a_0$ in A/B , so A/B is an one-trapped automaton.

Assume arbitrary $b \in B$, $v \in X^+$ and $w \in GDW(A)$. Then we have that $b = au$, for some $a \in A$ and $u \in GDW(A)$, and now $(bv)w = auvw = auw = bw$, by Lemma 1. This completes the proof of the implication (iii) \Rightarrow (ii).

(ii) \Rightarrow (iii). Let A be an extension of a locally directable automaton B by an one-trapped automaton A/B . Let $v \in LDW(B)$ and $u \in TW(A/B)$. Assume now arbitrary $a \in A$ and $w \in X^*$. Then $au \in B$, and since the subautomaton $S(au)$ of B generated by au is directable, with v as one of its directing words, and $au, auvw \in S(au)$, then $auv = auvwv$. Therefore, $uv \in GDW(A)$ and A is a generalized directable automaton. \square

Locally directable automata, that appear in the above theorem, will be characterized by the next theorem.

Theorem 2. *The following conditions on an automaton A are equivalent:*

- (i) $S(A)$ has a right zero;
- (ii) A is a direct sum of directable automata with the same directing word;
- (iii) A is a locally directable automaton.

If A is a finite automaton, then the condition (ii) can be replaced by the following condition:

- (ii') A is a direct sum of directable automata.

Proof. (i) \Leftrightarrow (iii). This follows by Lemma 3.

(iii) \Rightarrow (ii). Assume an arbitrary $u \in LDW(A)$ and define a relation ϱ on A by: $(a, b) \in \varrho \Leftrightarrow au = bu$. Obviously, ϱ is an equivalence relation on A and $(av, a) \in \varrho$, for all $a \in A$ and $v \in X^*$. Therefore, by Lemma 3.1 of [10] we have that ϱ is a direct sum congruence on A .

Let B be an arbitrary ϱ -class of A . Assume arbitrary $a, b \in B$. Then $au = bu$, so B is a directable automaton, with u as one of its directing words. This completes the proof of the implication (iii) \Rightarrow (ii).

(ii) \Rightarrow (iii). Let A be a direct sum of directable automata A_α , $\alpha \in Y$, and let there exist a word $u \in X^*$ such that it is a directing word for all A_α , $\alpha \in Y$. Assume arbitrary $a \in A$ and $v \in X^*$. Then $a, av \in A_\alpha$, for some $\alpha \in Y$, and since A_α is directable and $u \in DW(A_\alpha)$, then $avv = au$, which was to be proved.

If A is finite and if (ii') holds, then A is a direct sum of finitely many directed automata A_1, \dots, A_k , and if we assume an arbitrary $u_i \in DW(A_i)$, $i \in \{1, \dots, k\}$, then $u = u_1 \cdots u_k \in DW(A_i)$, for each $i \in \{1, \dots, k\}$, by Remark 3.2 of [18]. This completes the proof of the theorem. \square

The next our goal is to characterize automata whose transition semigroups have left zeroes.

Theorem 3. *The following conditions on an automaton A are equivalent:*

- (i) $S(A)$ has a left zero;
- (ii) A is an extension of a discrete automaton by an one-trapped automaton;
- (iii) A is a trapped automaton.

Proof. (i) \Leftrightarrow (iii). This follows by Lemma 3.

(iii) \Rightarrow (ii). By (i) \Leftrightarrow (iii) and Lemma 4, every trapped automaton A is a generalized directable automaton and $TW(A) = GDW(A)$. As was proved in (iii) \Rightarrow (ii) of Theorem 1, A is an extension of an automaton $B = \{au \mid a \in A, u \in GDW(A)\}$ by an one-trapped automaton, and since $GDW(A) = TW(A)$, then B is a discrete automaton.

(ii) \Rightarrow (iii). Let A be an extension of a discrete automaton B by an one-trapped automaton A/B and let $u \in Tr(A/B)$. Then for each $a \in A$ we have that $au \in B = Tr(A)$, so we have proved that A is trapped. \square

We will finish this section considering automata whose transition semigroups have a zero.

Theorem 4. *The following conditions on an automaton A are equivalent:*

- (i) $S(A)$ has a zero;
- (ii) A is a retractive extension of a discrete automaton by an one-trapped automaton;
- (iii) A is a direct sum of one-trapped automata with the same trapping word;
- (iv) A is a subdirect product of a discrete automaton and an one-trapped automaton;
- (v) A is a parallel composition of a discrete automaton and an one-trapped automaton;
- (vi) A is a locally one-trapped automaton;

If A is a finite automaton, then the condition (iii) can be replaced by the following condition:

(iii') A is a direct sum of one-trapped automata.

Proof. (i) \Leftrightarrow (vi). This follows by Lemma 3.

(vi) \Rightarrow (ii). Let A be a locally one-trapped automaton. Assume an arbitrary $u \in LOTW(A)$. Then A is trapped, and by Theorem 3, A is an extension of a discrete automaton $B = Tr(A)$ by a one-trapped automaton A/B . Define a mapping φ of A into B by: for $a \in A$, $a\varphi = au$. Since $au \in Tr(A)$ and A is locally one-trapped, for each $v \in X^*$ we have that $(av)\varphi = avu = au = auv = (a\varphi)v$, so φ is a homomorphism. On the other hand, if $a \in B$, then it is a trap and $a\varphi = au = a$. Therefore, φ is a retraction of A onto B , which was to be proved.

(ii) \Rightarrow (iii). Let A be a retractive extension of a discrete automaton B by a one-trapped automaton A/B . Let φ be a retraction of A onto B and let u be an arbitrary trapping word of A/B . For $b \in B$, let $A_b = b\varphi^{-1}$. Since an inverse homomorphic image of a subautomaton is also a subautomaton, then A_b , $b \in B$, are subautomata of A and A is a direct sum of these automata. Clearly, b is the unique trap of A_b and u is a trapping word of A_b . Thus, we have proved (iii).

(iii) \Rightarrow (iv). Let A be a direct sum of one-trapped automata A_α , $\alpha \in Y$, that have the same trapping word u . Let σ denote the corresponding direct sum congruence on A . As we know, A/σ is a discrete automaton. On the other hand, $B = Tr(A)$ is a subautomaton of A . Let ϱ denote the Rees congruence on A determined by B . Obviously, A/ϱ is an one-trapped automaton, with u as one of its trapping words. Finally, $\sigma \cap \varrho = \Delta$, since each σ -class contains exactly one trap of A . Here Δ denotes the equality relation on A . Therefore, A is a subdirect product of A/σ and A/ϱ , so we have proved (iv).

(iv) \Rightarrow (v). This implication is obvious.

(v) \Rightarrow (vi). Let A be a parallel composition of a discrete automaton B and a one-trapped automaton C . Let ϕ be an embedding of A into $B \times C$, and let u be an arbitrary trapping word of C . Assume arbitrary $a \in A$ and $p, q \in X^*$. Then $a\phi = (b, c)$ for some $b \in B$ and $c \in C$, so $(apuq)\phi = (a\phi)puq = (bpuq, cpuq) = (b, cu) = (bu, cu) = (a\phi)u = (au)\phi$, whence $apuq = au$, which was to be proved.

If A is finite and if (iii') holds, then A is a direct sum of finitely many one-trapped automata A_1, \dots, A_k , and if we assume an arbitrary $u_i \in TW(A_i)$, $i \in \{1, \dots, k\}$, then $u = u_1 \cdots u_k \in TW(A_i)$, for each $i \in \{1, \dots, k\}$, by Lemma 4. This completes the proof of the theorem. \square

3. Generalized definite automata

In this section we study the class of generalized definite automata and some of its well-known subclasses, from the aspect of properties of transition semigroups of automata belonging to these classes.

First we recall some known definitions. An automaton A is called a *definite automaton* if there exists $k \in \mathbb{N}$ such that $au = bu$, for all $a, b \in A$ and $u \in X^{\geq k}$, or

equivalently, if $X^{\geq k} \subseteq DW(A)$, for some $k \in \mathbb{N}$. The smallest number having this property is called the *degree of definiteness* of A . Similarly, A is called a *reverse definite automaton* if there exists $k \in \mathbb{N}$ such that $auv = au$, for all $a \in A, u \in X^{\geq k}$ and $v \in X^*$, that is, if $X^{\geq k} \subseteq TW(A)$, for some $k \in \mathbb{N}$. The smallest number having this property is called the *degree of reverse definiteness* of A .

An automaton A is called a *nilpotent automaton* if it has a unique trap and there exists $k \in \mathbb{N}$ such that each word $u \in X^{\geq k}$ is a trapping word. In other words, A is nilpotent if and only if there exists $k \in \mathbb{N}$ such that $auv = bu$, for all $a, b \in A, u \in X^{\geq k}$ and $v \in X^*$. The smallest number having this property is called the *degree of nilpotency* of A . An extension A of an automaton B will be called a *nilpotent extension* of B if the factor automaton A/B is nilpotent. Clearly, A is a nilpotent extension of B if and only if there exists $k \in \mathbb{N}$ such that $au \in B$ for all $a \in A$ and $u \in X^{\geq k}$.

As in the previous section, we give some new definitions regarding some "local" properties of automata. An automaton A will be called *locally definite* if all its monogenic subautomata are definite and their degrees of definiteness are bounded. For finite automata the second condition is obviously fulfilled and it can be omitted. Equivalently, A is locally definite if and only if there exists $k \in \mathbb{N}$ such that $avu = au$, for all $a \in A, v \in X^*$ and $u \in X^{\geq k}$.

Similarly, A is said to be *locally nilpotent* if all its monogenic subautomata are nilpotent and their degrees of nilpotency are bounded. As in the previous case, the second condition can be omitted for finite automata. In other words, A is locally nilpotent if and only if there exists $k \in \mathbb{N}$ such that $apqu = au$, for all $a \in A, p, q \in X^*$ and $u \in X^{\geq k}$.

Finally, by a *generalized definite automaton* we mean an automaton for which there exist $k, m \in \mathbb{N}$ such that $aupv = auqv$, for all $a \in A, p, q \in X^*, u \in X^{\geq k}$ and $v \in X^{\geq m}$. These automata are described by the following theorem:

Theorem 5. *The following conditions on an automaton A are equivalent:*

- (i) $S(A)$ is a nilpotent extension of a rectangular band;
- (ii) A is a nilpotent extension of a locally definite automaton;
- (iii) A is a generalized definite automaton;
- (iv) $(\exists k \in \mathbb{N})(\forall u \in X^{\geq k})(\forall a \in A)(\forall v \in X^*) auvu = au$.

Proof. (i) \Rightarrow (iii). Let S be a nilpotent extension of a rectangular band E , i.e. $S^k = E$, for some $k \in \mathbb{N}$. Assume arbitrary $u, v \in X^{\geq k}, p, q \in X^*$ and $a \in A$. Then $\eta_u, \eta_v \in E$, whence $\eta_{upv} = \eta_u \eta_p \eta_v = \eta_u \eta_v = \eta_u \eta_q \eta_v = \eta_{uqv}$, whence $aupv = auqv$, which was to be proved.

(iii) \Rightarrow (iv). If A is generalized definite, then there exist $m, n \in \mathbb{N}$ such that $aupv = auqv$, for all $a \in A, p, q \in X^*, u \in X^{\geq m}$ and $v \in X^{\geq n}$. Let $k = m + n, w \in X^{\geq k}, a \in A$ and $p \in X^*$. Then $w = uv$, for some $u \in X^{\geq m}$ and $v \in X^{\geq n}$, whence $awpw = au(vpu)v = auv = aw$. Therefore, (iv) holds.

(iv) \Rightarrow (i). We see that A is a generalized directable automaton, so S is an ideal extension of a rectangular band E consisting of all bi-zeroes of S . Moreover, the condition (iv) means that $X^{\geq k} \subseteq GDW(A)$, for some $k \in \mathbb{N}$, so we conclude the following: if $s \in S^k$, then $s = \eta_u$, where u can be chosen to be in $X^{\geq k}$, that is, to be in $GDW(A)$. Now by Lemmas 1 and 3 we have that $s = \eta_u \in E$. Therefore, $S^k = E$, which was to be proved.

(iv) \Rightarrow (ii). Since A is a generalized directable automaton, then by Theorem 1, it is an extension of a locally directable automaton $B = \{au \mid a \in A, u \in GDW(A)\}$ by a one-trapped automaton A/B . But, by (iv) we have that $X^{\geq k} \subseteq GDW(A)$, for some $k \in \mathbb{N}$, so $au \in B$, for any $a \in A$ and $u \in X^{\geq k}$. Therefore, A/B is a nilpotent automaton. Assume arbitrary $b \in B$, $u \in X^{\geq k}$ and $v \in X^*$. Then $b = aw$, for some $w \in X^{\geq k}$, so by Lemmas 1 and 3 it follows that $bvu = awvu = awu = bu$, since $u, w \in X^{\geq k} \subseteq GDW(A)$. Thus, B is locally definite.

(ii) \Rightarrow (iii). Let A be a nilpotent extension of a locally definite automaton B . Then there exists $k \in \mathbb{N}$ such that $au \in B$, for all $a \in A$ and $u \in X^{\geq k}$, and there exists $m \in \mathbb{N}$ such that $bvw = bv$, for all $b \in B$, $w \in X^*$ and $v \in X^{\geq m}$. Assume now arbitrary $u \in X^{\geq k}$, $v \in X^{\geq m}$, $a \in A$ and $p, q \in X^*$. Then $au \in B$ yields $aupv = (au)pv = (au)v = (au)qv = auqv$. Therefore, A is generalized definite. \square

The condition (iv) will be used here as a simpler definition of the generalized definiteness. Note again that this condition means that $X^{\geq k} \subseteq GDW(A)$, for some $k \in \mathbb{N}$.

Next we intend to describe structure of locally definite automata that appear in the preceding theorem.

Theorem 6. *The following conditions on an automaton A are equivalent:*

- (i) $S(A)$ is a nilpotent extension of a right zero band;
- (ii) A is a direct sum of definite automata with bounded degrees of definiteness;
- (iii) A is a locally definite automaton.

If A is a finite automaton, then the condition (ii) can be replaced by the following condition:

- (ii') A is a direct sum of definite automata.

Proof. (i) \Rightarrow (iii). Let S be a nilpotent extension of a right zero band E . Assume $k \in \mathbb{N}$ such that $S^k = E$. In view of Lemmas 1 and 3, $S^k = E$ implies that $X^{\geq k} \subseteq LDW(A)$, which is clearly equivalent to the condition (iii).

(iii) \Rightarrow (i). Clearly, A is generalized definite, so by Theorem 5 it follows that S is a nilpotent extension of a rectangular band E which consists of all bi-zeroes of S . On the other hand, A is locally directable, so by Theorem 2 and Lemmas 1 and 2 we have that E is also the set of all right zeroes of S , i.e. it is a right zero band.

(iii) \Rightarrow (ii). Assume $k \in \mathbb{N}$ such that $avu = au$, for all $a \in A$, $u \in X^{\geq k}$ and $v \in X^*$. Let a relation ρ on A be defined by: $(a, b) \in \rho \Leftrightarrow (\forall u \in X^{\geq k}) au = bu$.

It is easy to see that ρ is an equivalence relation on A . On the other hand, the definition of local definiteness implies that ρ is a direct sum congruence on A . Let B be an arbitrary ρ -class of A and $a, b \in B$. Then $au = bu$, for each $u \in X^{\geq k}$, so B is a definite automaton whose degree of definiteness does not exceed k . Therefore, (ii) holds.

(ii) \Rightarrow (iii). Let A be a direct sum of definite automata A_α , $\alpha \in Y$, and let k be a bound of their degrees of definiteness. Assume arbitrary $a \in A$, $v \in X^*$ and $u \in X^{\geq k}$. Then $a, av \in A_\alpha$, for some $\alpha \in Y$, so $avu = au$, since $u \in DW(A_\alpha)$. This proves (iii).

As in the proof of Theorem 2 we show that (ii) is equivalent to (ii') for all finite automata. \square

An automaton A is called a *reset automaton* if it is a definite automaton with the degree of definiteness equal to 1, that is if $ax = bx$, for all $a, b \in A$ and $x \in X$. If all monogenic subautomata of A are reset, we will say that A is a *locally reset automaton*. In other words, A is locally reset if and only if $aux = ax$, for all $a \in A$, $x \in X$ and $u \in X^*$. As an immediate consequence of the previous theorem we have the following:

Corollary 1. *The following conditions on an automaton A are equivalent:*

- (i) $S(A)$ is a right zero band;
- (ii) A is a direct sum of reset automata;
- (iii) A is a locally reset automaton.

Next we consider automata whose transition semigroups are nilpotent extensions of left zero bands.

Theorem 7. *The following conditions on an automaton A are equivalent:*

- (i) $S(A)$ is a nilpotent extension of a left zero band;
- (ii) A is a nilpotent extension of a discrete automaton;
- (iii) A is a reverse definite automaton.

Proof. (i) \Leftrightarrow (iii). Assume $k \in \mathbb{N}$ such that $S^k = E$ is a left zero band. Then $s \in E$ if and only if $s = \eta_u$, for some $u \in X^{\geq k}$, and, on the other hand, $\eta_u \in E$ if and only if $u \in TW(A)$. Therefore, S^k is a left zero band, for some $k \in \mathbb{N}$, if and only if A is reverse definite.

(iii) \Rightarrow (ii). By Theorem 3, A is an extension of a discrete automaton B by a one-trapped automaton A/B , and then $B = Tr(A)$. On the other hand, by (iii) it follows that there exists $k \in \mathbb{N}$ such that $au \in B$, for each $u \in X^{\geq k}$. Thus, A/B is a nilpotent automaton, which was to be proved.

(ii) \Rightarrow (iii). Let A be a nilpotent extension of a discrete automaton B . Clearly, $B = Tr(A)$. Let k be the degree of nilpotency of A/B , and assume arbitrary $u \in X^{\geq k}$, $a \in A$ and $v \in X^*$. Then $au \in B$, whence $auv = au$. Thus, A is reverse definite. \square

Theorem 8. *The following conditions on an automaton A are equivalent:*

- (i) $S(A)$ is a nilpotent semigroup;
- (ii) A is a retractive nilpotent extension of a discrete automaton;
- (iii) A is a direct sum of nilpotent automata with bounded degrees of nilpotency;
- (iv) A is a subdirect product of a discrete automaton and a nilpotent automaton;
- (v) A is a parallel composition of a discrete automaton and a nilpotent automaton;
- (vi) A is a locally nilpotent automaton;

If A is a finite automaton, then the condition (iii) can be replaced by the following condition:

- (iii') A is a direct sum of nilpotent automata.

Proof. Note that the equivalence of conditions (i) and (iii) was discovered by L. N. Shevrin in [29], and one proof of this assertion can be found in the book of F. Gécseg and I. Peák [14]. However, here we will give another proof of this assertion.

(i) \Leftrightarrow (vi). We see that A is locally nilpotent if and only if $X^{\geq k} \subseteq LOTW(A)$, for some $k \in \mathbb{N}$. But, this holds if and only if S has a zero 0 and $S^k = \{0\}$, for some $k \in \mathbb{N}$, by Lemma 3.

(vi) \Rightarrow (ii). By Theorem 4, A is a retractive extension of a discrete automaton B by an one-trapped automaton. On the other hand, by Theorem 7, A is a nilpotent extension of a discrete automaton C . Clearly, $B = C$, so (ii) is proved.

(ii) \Rightarrow (iii). This one proves similarly as the corresponding part of the proof of Theorem 4.

(iii) \Rightarrow (iv). Let A be a direct sum of nilpotent automata A_α , $\alpha \in Y$, and let k be a bound of the degrees of nilpotency of the summands A_α , $\alpha \in Y$. By the proof of Theorem 4, A is a subdirect product of a discrete automaton A/σ and an one-trapped automaton A/ϱ , where σ and ϱ are congruences on A defined as in the proof of Theorem 4. It is not hard to check that A/ϱ is a nilpotent automaton with the degree of nilpotency which does not exceed k .

(iv) \Rightarrow (v). This is obvious.

(v) \Rightarrow (vi). Let A be a parallel composition of a discrete automaton B and a nilpotent automaton C . Then $X^{\geq k} \subseteq LOTW(C)$, for some $k \in \mathbb{N}$, and if assume arbitrary $u \in X^{\geq k}$, $a \in A$ and $p, q \in X^*$, as in the proof of Theorem 4 we obtain that $ap u q = au$, which was to be proved.

The rest of the proof can be proved similarly as the related parts of the proof of Theorems 4 and 6. \square

Note that finite semigroups which are nilpotent extensions of rectangular bands are known as *locally trivial* semigroups. Languages that correspond to these semigroups, in the sense of the Eilenberg's theorem, were characterized in the book [28] by J. E. Pin. Languages that correspond to finite nilpotent semigroups, and finite semigroups which are nilpotent extensions of left and right zero bands, were also described in this book.

4. Characterizations through generalized varieties

Treatment of X -automata as unary algebras of type X gives possibility to study varieties of X -automata and certain their generalizations, such as generalized varieties and pseudo-varieties. In this section we use this possibility to characterize the classes considered in the previous two sections as generalized varieties of automata.

A class K of X -automata is called a *variety* if it is closed under homomorphisms, subautomata and direct products, a *generalized variety*, if it is closed under homomorphisms, subautomata, finite direct products and arbitrary direct powers, and it is called a *pseudo-variety* if it consists only of finite automata and it is closed under homomorphisms, subautomata and finite direct products. As was proved by C. J. Ash in [1], K is a generalized variety if and only if it is a directed union of varieties, and it is a pseudo-variety if and only if it is the intersection of some generalized variety and the pseudo-variety of all finite X -automata. Generalized varieties will be here usually denoted by bold face letters. For a generalized variety \mathbf{K} , the corresponding pseudo-variety, consisting of all finite automata from \mathbf{K} , will be denoted by $\underline{\mathbf{K}}$.

As known, a class of algebras of a given type τ is a variety if and only if it can be equationally defined, that is, if it is the class of all algebras of type τ that satisfy a given set of identities of type τ . It is also known that this set of identities can be chosen so that at most countably many variables occur in them. For automata, this set of variables can be obviously reduced to at most two variables. So we will consider identities of type X in at most two variables, that is, the identities of the form $gu = hv$ or $gu = gv$, where $u, v \in X^*$ and g and h are variables that take their values in the set of states of an automaton. If a family $\{gu_i = hv_i\}_{i \in I}$ of identities of type X is given, then $[gu_i = hv_i \mid i \in I]$ will denote the variety of X -automata determined by this family of identities.

We introduce the following notations:

Notation	Class of automata	Notation	Class of automata
GDir	generalized directable	GDef	generalized definite
LDir	locally directable	LDef	locally definite
Dir	directable	Def	definite
Trap	trapped	RDef	reverse definite
LOTrap	locally one-trapped	LNilp	locally nilpotent
OTrap	one-trapped	Nilp	nilpotent
D	discrete	O	trivial

Table 1

Let K_1 and K_2 be two classes of X -automata. Then their *Mal'cev product* $K_1 \circ K_2$ is defined as the class of all X -automata A such that there exists a congruence ϱ on A so that A/ϱ belongs to K_2 and every ϱ -class which is a subautomaton of A belongs to K_1 . For example, **OTrap** \circ K is the class of all extensions of automata from K by one-trapped automata, and **D** \circ K denotes the class of all automata that

are direct sums of automata from K . Especially, $\mathbf{D} \bullet \mathbf{Dir}$ will denote all direct sums of directable automata with the same directing word, $\mathbf{D} \bullet \mathbf{Def}$ will denote all direct sums of definite automata with bounded degrees of definiteness, $\mathbf{D} \bullet \mathbf{OTrap}$ will denote all direct sums of one-trapped automata with the same trapping word, and $\mathbf{D} \bullet \mathbf{Nilp}$ will denote all direct sums of nilpotent automata with bounded degrees of nilpotency.

Now we are ready to prove the following theorem:

Theorem 9. *The classes defined in Table 1 are pairwise different generalized varieties and the following figure represents their inclusion diagram:*

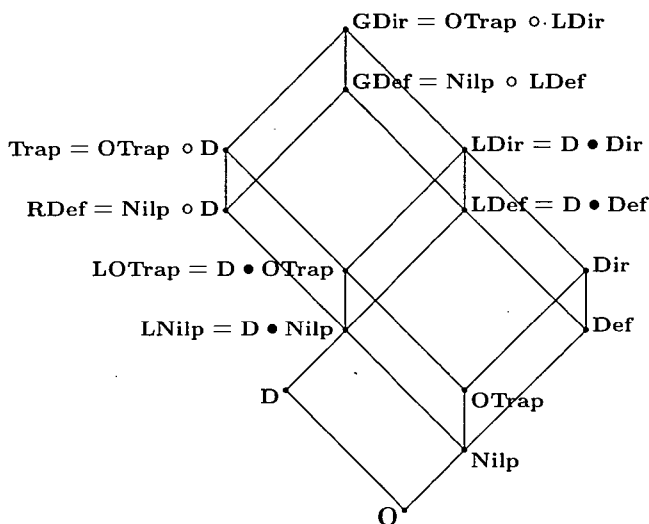

Moreover, they form a semilattice under the set intersection.

Proof. Clearly, \mathbf{D} and \mathbf{O} are varieties. Other classes can be represented in the following way:

$$\begin{aligned}
 \mathbf{GDir} &= \bigcup_{u \in X^*} [guwu = gu \mid w \in X^*], & \mathbf{GDef} &= \bigcup_{k \in \mathbb{N}} [guwu = gu \mid u \in X^{\geq k}, w \in X^*], \\
 \mathbf{Dir} &= \bigcup_{u \in X^*} [gu = hu], & \mathbf{Def} &= \bigcup_{k \in \mathbb{N}} [gu = hu \mid u \in X^{\geq k}], \\
 \mathbf{Trap} &= \bigcup_{u \in X^*} [guw = gu \mid w \in X^*], & \mathbf{RDef} &= \bigcup_{k \in \mathbb{N}} [guw = gu \mid u \in X^{\geq k}, w \in X^*], \\
 \mathbf{OTrap} &= \bigcup_{u \in X^*} [guw = hu \mid w \in X^*], & \mathbf{Nilp} &= \bigcup_{k \in \mathbb{N}} [guw = hu \mid u \in X^{\geq k}, w \in X^*], \\
 \mathbf{LDir} &= \bigcup_{u \in X^*} [gwu = gu \mid w \in X^*], & \mathbf{LDef} &= \bigcup_{k \in \mathbb{N}} [gwu = gu \mid u \in X^{\geq k}, w \in X^*], \\
 \mathbf{LOTrap} &= \bigcup_{u \in X^*} [gpuq = gu \mid p, q \in X^*], & \mathbf{LNilp} &= \bigcup_{k \in \mathbb{N}} [gpuq = gu \mid u \in X^{\geq k}, p, q \in X^*].
 \end{aligned}$$

On the other hand, since $GDW(A)$, $LDW(A)$ and $TW(A)$ and $LOTW(A)$, if they are non-empty, are ideals of X^* , for every X -automaton A , we have:

$$\begin{aligned}
 & [guwu = gu \mid w \in X^*], [gvwv = gv \mid w \in X^*] \subseteq [guvwvw = gvw \mid w \in X^*], \\
 & [gu = hu], [gv = hv] \subseteq [guv = huv], \\
 & [guw = gu \mid w \in X^*], [gvw = gv \mid w \in X^*] \subseteq [guvw = gvw \mid w \in X^*], \\
 & [guw = hu \mid w \in X^*], [gvw = hv \mid w \in X^*] \subseteq [guvw = huv \mid w \in X^*], \\
 & [gwu = gu \mid w \in X^*], [gqv = gv \mid w \in X^*] \subseteq [gquv = guv \mid w \in X^*], \\
 & [gpvq = gu \mid p, q \in X^*], [gpvq = gv \mid p, q \in X^*] \subseteq [gpvq = guv \mid p, q \in X^*],
 \end{aligned}$$

and for $m, k \in \mathbb{N}$, $m \geq k$ implies

$$\begin{aligned}
 & [guwu = gu \mid u \in X^{\geq k}, w \in X^*] \subseteq [guwu = gu \mid u \in X^{\geq m}, w \in X^*], \\
 & [gu = hu \mid u \in X^{\geq k}] \subseteq [gu = hu \mid u \in X^{\geq m}], \\
 & [guw = gu \mid u \in X^{\geq k}, w \in X^*] \subseteq [guw = gu \mid u \in X^{\geq m}, w \in X^*], \\
 & [guw = hu \mid u \in X^{\geq k}, w \in X^*] \subseteq [guw = hu \mid u \in X^{\geq m}, w \in X^*], \\
 & [gqu = gu \mid u \in X^{\geq k}, w \in X^*] \subseteq [gqu = gu \mid u \in X^{\geq m}, w \in X^*], \\
 & [gpvq = gu \mid u \in X^{\geq k}, p, q \in X^*] \subseteq [gpvq = gu \mid u \in X^{\geq m}, p, q \in X^*].
 \end{aligned}$$

Therefore, each of the above given unions is directed, that is, each of the given classes is a directed union of varieties, so by Theorem 1 of [1], they are generalized varieties.

It is not hard to verify that the above figure represents the inclusion diagram of the considered classes. This follows by the given representation of these generalized varieties and by Theorems 1–8. We will give some examples that verify that these inclusions are proper.

Let the input alphabet X be represented in the form $X = X_1 \cup X_2$, where $X_1 \neq \emptyset$, $X_2 \neq \emptyset$ and $X_1 \cap X_2 = \emptyset$. This is possible since the automata with the one-element input alphabets are out of consideration. Consider the automata constructed by the following figures:

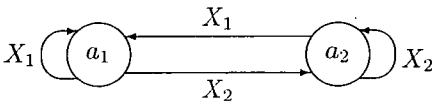

Fig. 1

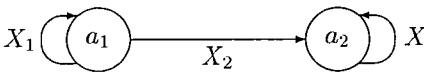

Fig. 2

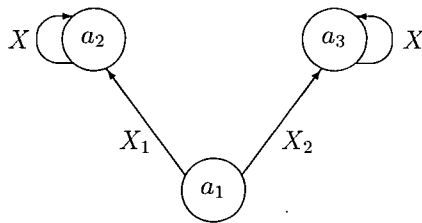

Fig. 3

The automaton from Fig. 1 is a two-element reset automaton and it belongs to

Def \ **Trap**, that yields the inclusions

$$\begin{array}{lll} \mathbf{Nilp} \subset \mathbf{Def}, & \mathbf{LNilp} \subset \mathbf{LDef}, & \mathbf{RDef} \subset \mathbf{GDef} \\ \mathbf{OTrap} \subset \mathbf{Dir}, & \mathbf{LOTrap} \subset \mathbf{LDir}, & \mathbf{Trap} \subset \mathbf{GDir}. \end{array}$$

The automaton given by Fig. 2 belongs to **OTrap** \ **GDef**, whence it follows that

$$\begin{array}{lll} \mathbf{Nilp} \subset \mathbf{OTrap}, & \mathbf{LNilp} \subset \mathbf{LOTrap}, & \mathbf{RDef} \subset \mathbf{Trap} \\ \mathbf{Def} \subset \mathbf{Dir}, & \mathbf{LDef} \subset \mathbf{LDir}, & \mathbf{GDef} \subset \mathbf{GDir}. \end{array}$$

The third automaton, defined by Fig. 3, belongs to **RDef** \ **LDir**, so we conclude that

$$\mathbf{LNilp} \subset \mathbf{RDef}, \quad \mathbf{LOTrap} \subset \mathbf{Trap}, \quad \mathbf{LDef} \subset \mathbf{GDef}, \quad \mathbf{LDir} \subset \mathbf{GDir}.$$

Assume an arbitrary $B \in \mathbf{Nilp}$. Let A be the direct sum of at least two isomorphic copies of B . Then A belongs to **LNilp** \ **Dir**, and this yields the inclusions

$$\mathbf{Nilp} \subset \mathbf{LNilp}, \quad \mathbf{OTrap} \subset \mathbf{LOTrap}, \quad \mathbf{Def} \subset \mathbf{LDef}, \quad \mathbf{Dir} \subset \mathbf{LDir}.$$

The inclusions $\mathbf{O} \subset \mathbf{Nilp}$, $\mathbf{O} \subset \mathbf{D}$ and $\mathbf{D} \subset \mathbf{LNilp}$ are obvious. Therefore, we have proved that all classes given in the above figure are different.

Further, assume $A \in \mathbf{Trap} \cap \mathbf{Dir}$. Then $TW(A) \neq \emptyset$ and $LDW(A) \neq \emptyset$, so $LOTW(A) \neq \emptyset$, by Lemma 4, whence $A \in \mathbf{LOTrap} = \mathbf{D} \bullet \mathbf{OTrap}$. But, A is direct sum indecomposable, since $A \in \mathbf{Dir}$, so $A \in \mathbf{OTrap}$. Thus, $\mathbf{Trap} \cap \mathbf{Dir} = \mathbf{OTrap}$. By this it also follows that $\mathbf{K} \cap \mathbf{Dir} = \mathbf{OTrap}$, for each \mathbf{K} from the figure such that $\mathbf{OTrap} \subseteq \mathbf{K} \subseteq \mathbf{Trap}$.

Let $A \in \mathbf{Trap} \cap \mathbf{Def}$. Then we also have $A \in \mathbf{OTrap}$ and $LOTW(A) = LDW(A) \neq \emptyset$. On the other hand, $A \in \mathbf{Def}$ implies that $X^{\geq k} \subseteq LDW(A)$, for some $k \in \mathbb{N}$, and now $X^{\geq k} \subseteq LOTW(A)$, whence $A \in \mathbf{Nilp}$. Thus, we have proved $\mathbf{Trap} \cap \mathbf{Dir} = \mathbf{Nilp}$, and this implies that $\mathbf{K} \cap \mathbf{Def} = \mathbf{Nilp}$, for each \mathbf{K} from the figure such that $\mathbf{Nilp} \subseteq \mathbf{K} \subseteq \mathbf{Trap}$.

In the same way we prove that $\mathbf{Trap} \cap \mathbf{LDir} = \mathbf{LOTrap}$ and $\mathbf{Trap} \cap \mathbf{LDef} = \mathbf{LNilp}$, that implies that $\mathbf{K} \cap \mathbf{LDef} = \mathbf{LNilp}$, for each \mathbf{K} from the figure such that $\mathbf{LNilp} \subseteq \mathbf{K} \subseteq \mathbf{Trap}$. Finally, it is clear that $\mathbf{D} \cap \mathbf{K} = \mathbf{O}$, for every \mathbf{K} from the figure such that $\mathbf{K} \subseteq \mathbf{Dir}$.

Therefore, the above diagram represents a semilattice under the set intersection. This completes the proof of the theorem. \square

An immediate consequence of the previous theorem is its analogue concerning related pseudo-varieties.

Corollary 2. *The classes given in the following figure are pairwise different pseudo-varieties and the figure represents their inclusion diagram:*

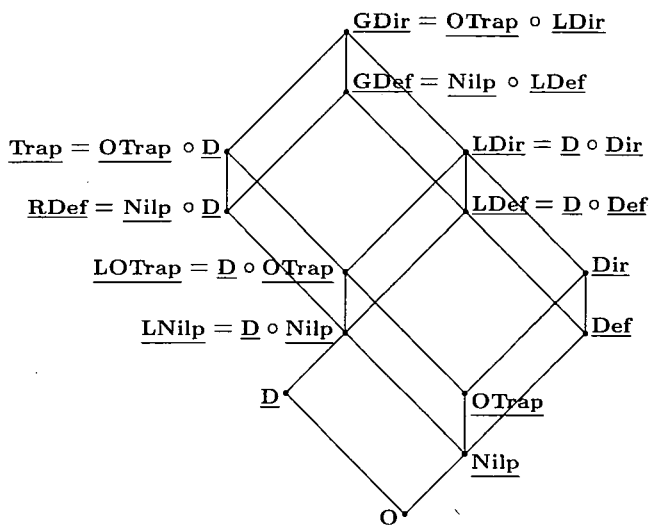

Remark 1. Previously we considered only automata with at least two input letters. In the case of *autonomous automata*, i.e. the automata whose input alphabet is one-element, we have that only the classes **Nilp**, **LNilp**, **O** and **D** are different since the transition semigroup of an autonomous automaton is monogenic.

References

- [1] C. J. Ash,, Pseudovarieties, generalized varieties and similarly described classes, *J. Algebra* **92** (1985), 104–115.
- [2] I. Babcsányi, Rees automaták, *Matematikai Lapok* **29** (1977-81), no. 1–3, 139–148 (in Hungarian).
- [3] I. Babcsányi and A. Nagy, Right-group type automata, *Acta Cybernetica* **12** (1995), 131–136.
- [4] S. Bogdanović and M. Ćirić, A note on congruences on algebras, in *Proc. of II Math. Conf. in Priština 1996*, Lj. D. Kočinac ed., Priština, 1997, pp. 67–72.
- [5] J. A. Brzozowski, Canonical regular expressions and minimal state graphs for definite events, *Proc. Symp. Math. Theory of Automata*, Microwave Research Inst. Symp. Ser. **12** (Brooklyn, 1963), New York, 1963, pp. 529–561.
- [6] S. Burris and H. P. Sankappanavar, *A course in universal algebra*, Springer-Verlag, New York, 1981.

- [7] J. Černý, Poznámka k homogénnym experimentom s konečnými automatami, *Mat.-fyz. cas. SAV* **14** (1964), 208–215.
- [8] J. Černý, A. Pirická and B. Rosenauerová, On directable automata, *Kybernetika* **7** (1971), no. 4, 289–298.
- [9] M. Ćirić and S. Bogdanović, Posets of \mathcal{C} -congruences, *Algebra Universalis* **36** (1996), 423–424.
- [10] M. Ćirić and S. Bogdanović, Lattices of subautomata and direct sum decompositions of automata, *Algebra Colloq.* (to appear).
- [11] M. Ćirić, S. Bogdanović and T. Petković, The lattice of positive quasi-orders on an automaton, *Facta Universitatis (Niš) Ser. Math. Inform.* **11**, (1996), 143–156.
- [12] M. Ćirić, S. Bogdanović and T. Petković, The lattice of subautomata of an automaton (a brief survey), *Proceedings of the Conference LIRA '97*, (to appear).
- [13] P. Dömösi, On temporal products of automata, *Papers on Automata and Languages X*, Dept. of Math. Karl Marx Univ. of Economics, Budapest, 1988–1, pp. 49–62.
- [14] F. Gécseg and I. Peák, *Algebraic Theory of Automata*, Akadémiai Kiadó, Budapest, 1972.
- [15] A. Ginzburg, About some properties of definite, reverse definite and related automata, *IEEE Trans. Electronic Computers* **EC-15** (1966), 809–810.
- [16] V. M. Glushkov, Abstract automata and partitions of free semigroups, *DAN SSSR* **136** (1961), 765–767 (in Russian).
- [17] J. M. Howie, *Fundamentals of Semigroup Theory*, London Math. Soc. monographs, New Series, Clarendon Press, Oxford, 1995.
- [18] B. Imreh and M. Steinby, Some remarks on directable automata, *Acta Cybernetica* **12**, (1995), no. 1, 23–35.
- [19] M. Ito and J. Duske, On cofinal and definite automata, *Acta Cybernetica* **6** (1983), no. 2, 181–189.
- [20] S. C. Kleene, Representation of events in nerve nets and finite automata, *Automata Studies*, Princeton University Press, Princeton, N.J., 1956, pp. 3–41.
- [21] W. Lex and R. Wiegandt, Torsion theory for acts, *Studia Sci. Math. Hungar.* **16** (1981), 263–280.
- [22] A. Nagy, Boolean type retractable automata with traps, *Acta Cybernetica* **10** (1991), no. 1–2, 53–64.

- [23] I. Peák, Automata and semigroups I, *Acta Sci. Math. (Szeged)* **25** (1964), 193–201 (in Russian).
- [24] I. Peák, Automata and semigroups II, *Acta Sci. Math. (Szeged)* **26** (1965), 49–54 (in Russian).
- [25] M. Perles, M. O. Rabin and E. Shamir, The theory of definite automata, *IEEE Trans. Electronic Computers* **EC-12** (1963), 233–243.
- [26] J. E. Pin, Sur les mots synchronisants dans un automata fini, *Elektron. Inform. Verarb. u. Kybernetik, EIK* **14** (1978), 297–303.
- [27] J. E. Pin, Sur un cas particulier de la conjecture de Cerny, *Automata, langages and programming*, ICALP'79 (Proc. Coll., Udine, 1979), Lect. Notes. Comp. Sci. **62**, Springer-Verlag, Berlin, 1979, pp. 345–352.
- [28] J. E. Pin, *Variétés de langages formels*, Masson, Paris, 1984.
- [29] L. N. Shevrin, About some classes of abstract automata, *Uspehi matem. nauk* **17:6 108** (1962), p. 219 (in Russian).
- [30] P. H. Starke, *Abstrakte Automaten*, VEB Deutscher Verlag der Wissenschaften, Berlin, 1969.
- [31] M. Steinby, On definite automata and related systems, *Ann. Acad. Sci. Fenn.*, Ser. A, I. *Mathematica* **444**, 1969.
- [32] M. Steinby, Classifying regular languages by their syntactic algebras, in: *Results and trends in theoretical computer science* (Graz, 1994), *Lect. Notes in Comput. Sci.*, **812**, Springer, Berlin, 1994, pp. 396–409.

Received January, 1998